

# Comparison of Low Rise Residential Industrialized Building Systems in Turkey\*

Semih Goksel Yildirim

Istanbul Arel University, Istanbul, Turkey

Industrialized building systems came into the agenda in response to requirements of earthquake resistance and rapid construction in Turkey after 1999 Izmit earthquake. CFS (cold-formed steel) framing system is able to meet the existing requirements in the field of low rise residential. But, objective comparison is required for the selection of structural systems used in low rise residential. CFS system is compared with timber frame and reinforced concrete building systems in terms of design and applicability criterion in circumstances of Turkey, and the results of this comparison are presented in this study. In order to compare building systems objectively, a sample project, has been designed and studied on it. Three structural systems have been separately applied over this project designed in consideration of existing housing stock and preferences of the construction industry of Turkey. Evaluation method with different values is selected in comparison and properties of three different structural systems are graded according to evaluation method. As a result of comparison, the CFS system is the most advantageous low rise residential prefabricated construction system in terms of design and applicability.

*Keywords:* low rise residential, industrialization, prefabricated reinforced concrete system, CFS (cold-formed steel) frame, timber frame

## Introduction

Demand for housing continues to rise in Turkey due to existing speed of population growth and approximately 600,000 units of residential production including renovation is required. Low rise residential (1-3 storey) are commonly found in existing housing stock with 85% (TSI (Turkish Statistical Institute), 2000, 2006). Concern to earthquake, resistant building technologies was increased in Turkish construction industry after 1999 Izmit earthquake. Moreover, declining of interest after 2004 accelerated construction industry which was developing slowly for so many years (YEM (Information Source of the Building Industry), 2007). Therefore, rapid construction has gained importance in the selection of structural system and so industrialization in construction is required due to technical and economical reasons. CFS (cold-formed steel) system is able to meet this requirement. Design, production, and installation features of alternative structural systems are effective in the selection of structural system of a building. In the context of Turkey, comparison of CFS system with other alternative low rise residential construction systems is required based on design and applicability criteria.

---

\* Presented in *38th IAHS World Congress on Housing Science*, April 16-19, 2012, International Association for Housing Science—Istanbul Technical University, Istanbul, Turkey, and only the abstract has been published in conference proceeding.  
Semih Goksel Yildirim, assistant professor, Ph.D., Department of Architecture, Istanbul Arel University.

Comparison based on these criteria mentioned as design and applicability is presented in this study.

### Properties of the Project Used for Comparison

Prefabricated R.C. (reinforced concrete) systems, CFS framing systems and timber frame systems came into the Turkish construction agenda as alternatives to conventional reinforced concrete systems after the 1999 Izmit earthquake. Sub-categories of prefabricated R.C., CFS, and timber frame systems which comply with prefabrication rules are selected and compared. Differences and reasons for preference of CFS system to other alternative systems are examined through this comparison. Prefabricated building systems for comparison are as follows: (1) Prefabricated System 1: Prefabricated R.C. stick system (floor/wall elements comprising of airated concrete panels); (2) Prefabricated System 2: Timber frame platform system; and (3) Prefabricated System 3: CFS frame platform system.

A project for comparison is designed according to building standards and regulations and the most preferred building proportion, residential area, and number of rooms in Turkey (see Figure 1). A layout where three prefabricated structural system can be separately applied, has been chosen. Objective and fair comparison is aimed as anticipating not to be affect the architectural layout by the difference of structural system. The design datum are presented in Table 1 and layouts of structural components are presented in Figure 2.



Figure 1. Typical project for comparison of structural systems.

Table 1

#### Design Data

City	Total land area	Unit lot area	Total house unit	Unit building floor area	Storey	Unit building floor space	Building type	Resident/ house	Density (resident/hectar)	Eaves height (h)
Istanbul	11.106 m <sup>2</sup> (-1 hectar)	430 m <sup>2</sup>	24	74 m <sup>2</sup>	2	148 m <sup>2</sup>	Detached	4	86 (low density)	6.50 m

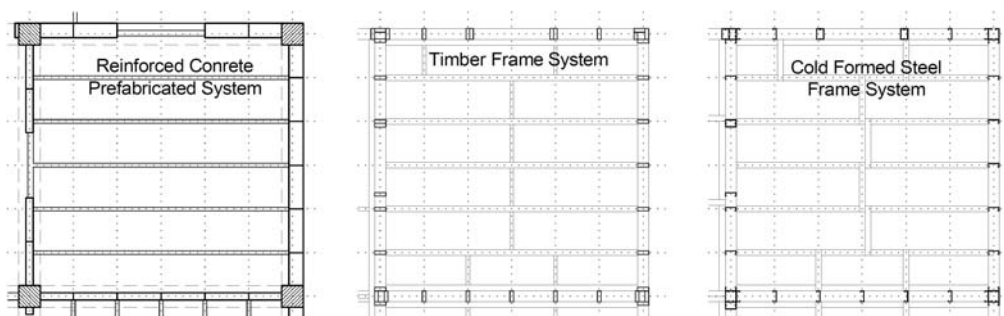

Figure 2. Layouts of structural components belong to typical project (upper floor).

### Insulation Layers

Considering as an objective comparison between prefabricated systems, three different construction systems shall separately supply the same conditions of building comfort through insulation layers according to the related building regulations (see Figure 3) (TS (Turkish Standards) 825, 2008). Since supplying same building comfort conditions in terms of sound and thermal insulations, comparison can be made at the level of structural and covering.

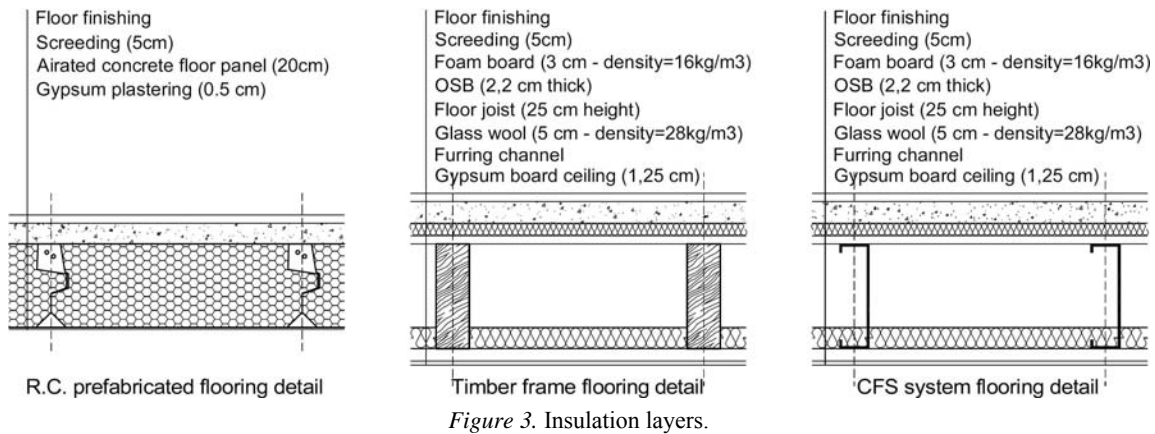

Figure 3. Insulation layers.

Floor and wall elements are preferred as airated concrete panels in System 1. The reason for using airated concrete panels as a constructional component is to obtain directly over stock. Airated concrete wall panel 20 cm thick exterior wall, 10 cm thick interior wall and airated concrete floor panel 20 cm thick are used in the project (Ayaydin & Koman, 2004; YTONG (aerated concrete manufacturer), 2008).

Load bearing exterior and interior walls are designed as 15 cm thick because of having load bearing capacity and ease of piping and non-load bearing walls are designed as 10 cm thick in Systems 2 and 3. Glasswool between exterior wall studs and glasswool bat over the roof floor are located for thermal and sound insulation. Moreover, high density foamboard is covered over the whole facade to prevent cold bridge. In addition, glass wool between interior wall stud and floor joist are applied for sound insulation (AISI (American Iron and Steel Institute), 2001; SFA (Steel Framing Alliance), 2000).

Physical properties such as weight, coefficient of heat conductivity, and type of fire resistance of used materials at wall and floor layers are taken from related local regulations and standards.

### Modular Coordination Rules

41 cm (16 inch), 48 cm (18 inch), and 61 cm (24 inch) modular dimensions (spacings) are defined in the horizontal plane for CFS and timber frame systems in international standards and specifications. Having been two-storey building and maximum 480 cm floor span, 61 cm (16 inch) basic module is accepted for modular grid at three structural systems. Dimensions of OSB (oriented strand board) and gypsum board panels used as covering in CFS and timber frame systems are effective in acceptance of 61 cm (16 inch) basic module. Beside, modular dimension of aerated concrete panels are available widely in the construction market and used in prefabricated R.C. systems, conforms with this basic module. However, 60 cm is applied instead of 61 cm as the basic module, because of ease of measurement and calculation in SI (metric) system.

### Structural Design

Three different structural systems are separately implemented for over the designed project, structurally analyzed and sections determined. Live and dead loads are taken from existing Turkish Standards (TS 498, 1997). Prefabricated R.C. stick system is structurally designed according to existing constructional standards and regulations in Turkey. Also, YTONG firm catalog is utilised in order to determine the thickness of airated concrete floor panels.

Publications of AWC (American Wood Council) are used for timber frame system design and “Kıvalı Ahşap Yapılar”, which is a manufacturer of timber frame buildings in Turkey, assisted in the design process.

Publications of SFA (Steel Framing Alliance) and AISI (American Iron and Steel Institute) are used for cold formed steel framing system design and “Aksan Yapı”, which is a manufacturer of cold formed steel frame buildings in Turkey, assisted in the design process.

As a result of these studies, sections of structural elements are determined as shown in Figure 4.

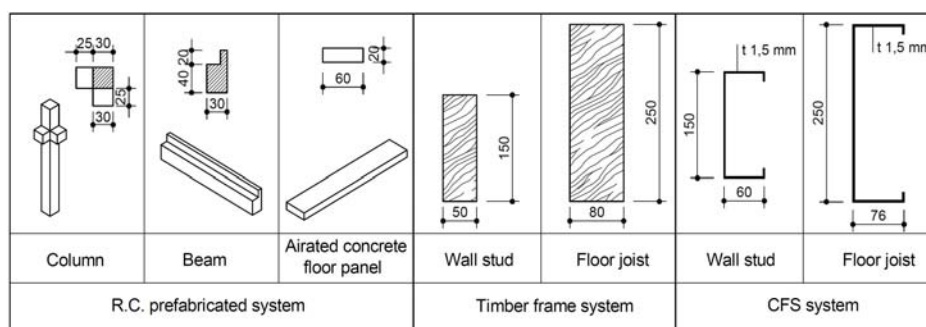

Figure 4. Structural component types.

### Evaluation Method

Method of “evaluation with different importance ratio of asset criteria and sub-purpose” is applied in this study. Firstly, importance ratios of sub-purposes (G) that depends on an evaluation system are determined. Secondly, sub-purposes are analysed according to the fulfillment of these sub-purposes, than sub-purpose value (B/b) is decided. Finally, utility value (fd) is calculated according to the importance ratio of each item. Definitions of abbreviations used in the evaluation method are shown in Table 2 (Tapan, 2004).

Table 2

*Definitions of Abbreviations Used in Evaluation Method*

G = importance ratio of sub-purpose	g = importance ratio of asset criteria	
B = sub-purpose value	b = value of asset criteria	Fd = utility value

A measurement scale is chosen according to the properties of each asset criteria or sub-purpose. Values from the worst to the best are determined from Table 3.

Table 3

*Numerical Measurement Scale (B/b)*

1	2	3	4	5
very bad	bad	sufficient	good	very good

### Comparison of Industrialized Building Systems

Prefabricated R.C. system, CFS system and timber frame system are compared according to the design and applicability criterion, and the results of this comparison are presented in Table 4. This comparison through constructional systems can be used in the selection of structural systems for low rise residential. The comparison consists of in total eighteen criterion as shown in Table 4 (Yıldırım, 2010). Also, some comments and data belonging to these criterion are presented below.

(1) Publications of some standards used for design of timber frame and CFS systems are in English language, therefore usage of these publications is limited at national level. Current timber frame standard in 1998 disaster specification is abrogated by becoming valid of 2007 earthquake specification (SSBDA (Specifications for structures to be built in disaster areas), 1998; SBBEZ (Specifications for buildings to be built in earthquake zones), 2007). Additionally structural design rules and load calculation methods for timber frame and CFS systems are defined in specifications and regulations of this item. But rules for architectural design do not exist in these standards, therefore, usage of international specifications is required. Consequently, problems occur during the design and approval of timber frame and CFS system in terms of existing local standards.

(2) Current standards are related to dimensioning of airated concrete floor panel.

(3) Separated division does not exist for timber frame and CFS systems in 2007 earthquake specification, but it is only mentioned in item 1.1.7: “*international specifications shall be used for designing of the buildings of which is out of scope of this regulation until publishing related own local regulations*” and “*any building shall supply general conditions mentioned in second division*”.

(4) The standard has been published in English language.

(5) Timber frame system is 1.5 times and prefabricated R.C. system is 12.5 times heavier than CFS system if compared only to the weight of structural elements.

(6) Timber frame system is 1.14 times and prefabricated R.C. system is four times heavier than CFS system if compared to the weight of structural and covering elements (since fulfilling same building comfort conditions). Because of having less dead load in timber frame and CFS systems, sections used in foundations become smaller and leads to material saving.

(7) Since, airated concrete panel is preferred as prefabricated floor panel in this project, limits of airated concrete panels available from construction market are shown in the table. Besides, different limits can be applied if prefabricated R.C. floor panels (solid section, hollow section, flat slab, coffered slab, etc.) were used.

(8) The effective floor span of timber frame and CFS systems is approximately defined as max. 7.3 m in international standards (SFA (Steel Framing Alliance), 2000; CSSBI (Canadian Sheet Steel Building Institute), 2005). Considering living room which has the longest span in a residential, this length, that is mostly preferred, is adequate in terms of crossing by rational and economical structural components. Different technological solutions and limitations can be applied at different building types.

(9) Load bearing capacity of CFS system can be increased by increasing thickness (1.0, 1.5, 2.0, 2.5 mm) of galvanized profiles as system component. In this case, dimensioning of system component according to load bearing capacity does not affect architectural design and detailing.

Table 4  
Comparison of Alternative Structural Systems

COMPARISON THROUGH STRUCTURAL SYSTEMS		SYSTEM 1	SYSTEM 2	SYSTEM 3	SUB- PURPOSE / ASSET CRITERIAS		SYSTEM 1		SYSTEM 2		SYSTEM 3		
		PREFABRICATED R.C.SKELETON HOUSING SYSTEM	TIMBER FRAME HOUSING SYSTEM	COLD FORMED STEEL FRAME HOUSING SYSTEM			PREFABRICATED R.C.SKELETON HOUSING SYSTEM		TIMBER FRAME HOUSING SYSTEM		COLD FORMED STEEL FRAME HOUSING SYSTEM		
		G	g	B/b	Fd	B/b	Fd	B/b	Fd				
APPLICABILITY CRITERIAS	1	BUILDING PROPORTION ACC. TO REGULATIONS	DETACHED & ADJACENT	DETACHED	DETACHED & ADJACENT	15%	100%	3	0,45	2	0,30	3	0,45
	2	ACTUAL REGULATIONS AND STANDARDS (1)	DBYBHY-2007 TS 498, TS 500, TS 9967, TS 3233, TS 453 (2), TS EN 991(2)	DBYBHY-2007 (3) TS 498, TS 647, TS EN 1995-1-1 (4), AWC Standards	DBYBHY-2007 (3) TS 498, TS-11372, TS EN 1993-1-3 (4), TS 914 EN ISO 1461 TS EN 10327, AISI & NASFA standards	15%	100%	3	0,45	1	0,15	2	0,30
	3	MAX. NUMBER OF STOREY ACC. TO REGULATIONS & TECHNICAL LIMITATIONS	3 +	2	3	15%	100%	3	0,45	2	0,30	3	0,45
DESIGN CRITERIAS	4	RESSISTANCE TO EARTHQUAKE	HEAVY SYSTEM	LIGHT SYSTEM	LIGHT SYSTEM	20%	100%	2	0,40	4	0,80	5	1,00
	4,1	STRUCTURAL WEIGHT (5)	84,79 ton	10,10 ton	6,70 ton								
	4,2	STR.+ COVERING WEIGHT (6)	100,00 ton	27,88 ton	24,51 ton								
	5	SPAN AT FLOORING	max. 6 m (7)	max. 7,2 m (8)	max. 7,3 m (8)	2%	100%	2	0,04	3	0,06	3	0,06
	6	HEIGHT OF COLUMN / STUD	> 3 m	max. 3 m	max. 3 m	2%	100%	3	0,06	3	0,06	3	0,06
	7	CANTILEVER	max. 60 cm (7)	max. 120 cm	max. 120 cm	2%	100%	2	0,04	3	0,06	3	0,06
	8	MODULAR COORDINATION	THICKNESS OF COLUMN & WALL ARE DIFFERENT	THICKNESS OF STUD & WALL ARE NOT DIFFERENT	THICKNESS OF STUD & WALL ARE NOT DIFFERENT	5%	100%	3	0,15	5	0,25	5	0,25
	9	COMPONENT TYPE	COLUMN, BEAM & FLOOR PANEL ARE SOLID SECTIONS	STUD & JOIST ARE SMALL SOLID SECTIONS	STUD & JOIST ARE SMALL HOLLOW SECTIONS (9)	5%	100%	3	0,15	4	0,20	5	0,25
	10	COMPONENT NUMBER	15	7	13	3%	100%	3	0,09	5	0,15	4	0,12
	11	COMPONENT OF STAIRCASE SUPPORT (12)	DIFFERENT TYPE WITH BUILDING STRUC. COMPONENT	SAME TYPE WITH BUILDING STRUC. COMPONENT	SAME TYPE WITH BUILDING STRUC. COMPONENT	2%	100%	1	0,02	3	0,06	3	0,06
	12	SOLUTION OF ROUND LAYOUT	YES (special solution is required)	YES	YES	2%	100%	1	0,02	3	0,06	3	0,06
	13	GALLERY IN LAYOUT	POSSIBLE	POSSIBLE	POSSIBLE	2%	100%	3	0,06	3	0,06	3	0,06
	14	ADDITION OR SUBTRACTION ON LAYOUT(10)	LIMITED	POSSIBLE	POSSIBLE	2%	100%	2	0,04	3	0,06	3	0,06
	15	WINDOW PROPORTION	FREE	LIMITED	LIMITED	2%	100%	3	0,06	2	0,04	2	0,04
	16	TERRACE ROOF	YES (laying bitum. membrane by fire)	YES (EPDM sheet or liquid water proof)	YES (EPDM sheet or liquid water proof)	2%	100%	3	0,06	3	0,06	3	0,06
17	COMPUTER SOFTWARE USED FOR STRUCT. DESIGN (11)	SPECIAL (ONLY BELONGS TO FIRM)	SPECIAL (ONLY BELONGS TO FIRM)	SPECIAL (ONLY BELONGS TO FIRM)	2%	100%	2	0,04	2	0,04	2	0,04	
18	DESIGN CHANGE AFTER CONSTRUCTION	DIFFICULT	POSSIBLE	POSSIBLE	2%	100%	1	0,02	3	0,06	3	0,06	
<b>TOTAL</b>						<b>100%</b>		<b>2,60</b>		<b>2,77</b>		<b>3,44</b>	
<b>RANKING</b>								<b>3</b>		<b>2</b>		<b>1</b>	

(10) Addition or subtraction is possible by use of beams, which is continuous of centrelines of column and main edge beams. Stairwell and balcony above entrance seem to be solved in System 1, but have some problems in terms of its structure. Whereas, floor joists can be easily extended due to design in timber frame and CFS systems independently from edge beams. This supplies flexibility in design.

(11) Existing standards and regulations in Turkey shall be defined in computer software used in load calculations.

(12) Staircase can be constructed with the same structural components, without requirement of different types of components in timber frame and CFS systems. But, special component belonging only to the staircase is required in the prefabricated R.C. system. Steps integrate more easily with structural system in terms of detailing in timber frame and CFS system than prefabricated R.C. system. However, steps can be supported by non-load bearing walls. Consequently, timber frame and CFS systems have design flexibility in terms of location and dimension of staircase than in a prefabricated R.C. system.

### Conclusions

In conclusion, the CFS system is the most advantageous low rise residential prefabricated construction system according to the comparison table (see Table 4). The advantages of CFS system in the basis of design and applicability criteria are summerized as shown below:

CFS system is more advantageous than timber frame system in terms of building proportion (as detached and adjacent) and number of stories according to town-planning codes. Timber frame system is 1.5 times and prefabricated R.C. system is 12.5 times heavier than CFS system if compared only to the weight of structural elements. CFS system has small hollow sections as component type meaning that the load bearing capacity according to its weight is higher than it is in timber frame system. Thickness of wall section and column are different in prefabricated R.C. system but there is not a projecting part on the wall surface for CFS system like that of prefabricated R.C. system. Compensation of planning modification is possible during production phase.

### References

- AISI (American Iron and Steel Institute). (2001). *Standard for cold-formed steel framing—General provisions, AISI/COFS/GP 2001*. Washington: American Iron and Steel Institute.
- Ayaydin, Y., & Koman, İ. (2004). *Concrete prefabrication in 12 question*. Istanbul: Information Source of the Building Industry (YEM).
- CSSBI (Canadian Sheet Steel Building Institute). (2005). *The lightweight steel frame house construction handbook*. Canada: Canadian Sheet Steel Building Institute (CSSBI).
- IMM (Istanbul Metropolitan Municipality). (2007). *Regulation of Istanbul development plan*. Istanbul: Istanbul Metropolitan Municipality, Istanbul.
- SBBEZ (Specifications for buildings to be built in earthquake zones). (2007). Ankara: Ministry of Public Works and Settlement, Government of Republic of Turkey.
- SFA (Steel Framing Alliance). (2000). *Prescriptive method for residential cold formed steel framing*. Chicago: Steel Framing Alliance (SFA).
- SSBDA (Specifications for structures to be built in disaster areas). (1998). Ankara: Ministry of Public Works and Settlement, Government of Republic of Turkey.
- Tapan, M. (2004). *Evaluation in architecture*. Istanbul: Istanbul Technical University publication.
- TS (Turkish Standards) 498. (1997). *Design loads for buildings*. Ankara: Turkish Standards Institution.

- TS 825. (2008). *Thermal insulation requirements for buildings*. Ankara: Turkish Standards Institution.
- TSI (Turkish Statistical Institute). (2000). *Result of 2000 building statistical*. Ankara: Turkish Statistical Institute.
- TSI. (2006). *2006 statistical annual of Turkey*. Ankara: Turkish Statistical Institute.
- YEM (Information Source of the Building Industry). (2007). *Report of 2007 Turkish building sector*. Istanbul: The Building Information Centre, Istanbul.
- Yıldırım, S. G. (2010). *The proposal of semi-open cold formed steel framing system for low rise residential in Turkey* (Ph.D. thesis, Istanbul Technical University, Institute of Science and Technology, Istanbul).
- YTONG (aerated concrete manufacturer). (2008). *Aerated concrete building components catalogue*. Retrieved from <http://www.ytong.com.tr>