

A Mixed-Mode Biquad Employing OTAs and Grounded Capacitors

Takao Tsukutani¹, Yasutomo Kinugasa¹ and Noburu Yabuki²

1. National Institute of Technology, Matsue College, Matsue 690-8518, Japan

2. National Institute of Technology, Tsuyama College, Tsuyama 708-8509, Japan

Abstract: This paper introduces a mixed-mode biquad employing OTAs (operational trans-conductance amplifiers) and grounded capacitors. The circuit can perform mixed-mode operation by selecting the input and output terminals. Additionally, the circuit enables low-pass, band-pass, high-pass, band-stop and all-pass transfer functions suitably choosing the input terminals. The circuit parameters ω_0 and Q can be tuned orthogonally through adjusting the trans-conductance gains of the OTAs. The biquad enjoys very low sensitivities with respect to the circuit active and passive components. The achievement examples are given together with simulation results by PSPICE.

Key words: Active circuit, mixed-mode operation, biquad characteristics, OTAs.

1. Introduction

High performance active circuits have received much attention. It is well known that the OTA (operational trans-conductance amplifier) provides highly linear electronic tunability and wide tunable range of its trans-conductance gain. Additionally, OTA-based circuit requires no external resistors, hence it is very suitable for monolithic integration. The current-mode and voltage-mode biquads using the OTAs have been discussed previously [1-6].

It is much desirable for the biquad circuit design that various circuit characteristics can be realized with no component matching conditions. Additionally, it is required to set the circuit parameters ω_0 , Q and H orthogonally or independently. In applications to analogue signal processing, it may be desirable to synthesize mixed-mode biquad with input current or voltage and output current or voltage. The mixed-mode biquad using six OTAs and two grounded capacitors has already been reported in the past [1]. However, the mixed-mode biquad with

above-mentioned performances has not yet been studied sufficiently.

This paper introduces a mixed-mode biquad employing five OTAs and two grounded capacitors. The biquadratic circuit can perform the current-mode, voltage-mode, trans-admittance-mode and trans-impedance-mode operations by selecting the input and output terminals. Additionally, the circuit enables LP (low-pass), BP (band-pass), HP (high-pass), BS (band-stop) and AP (all-pass) characteristics suitably choosing the input terminals. The circuit parameters ω_0 and Q can be tuned orthogonally through adjusting the trans-conductance gains of the OTAs. It is made clear from sensitivity analysis that the circuit enjoys very low sensitivities to the circuit active and passive components. The achievement examples are given together with simulation results by PSPICE.

2. OTA

Fig. 1 shows the symbol for the OTA. This shows dual current output OTA.

The current output I_o is given by:

$$I_o = \pm g_m (V_+ - V_-) \quad (1)$$

Corresponding author: Takao Tsukutani, Dr., research field: analog signal processing.

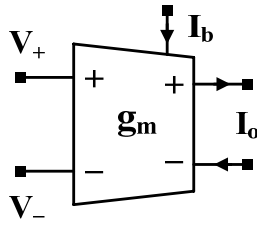

Fig. 1 Symbol for OTA.

where g_m denotes the trans-conductance gain.

In Eq. (1), the sign “ \pm ” shows the polarity of the current output.

The OTA [2] with MOS transistors is shown in Fig. 2. The trans-conductance gain g_m can be characterized by:

$$g_m = \sqrt{\mu_n C_{ox} \frac{W}{L} I_b} \quad (2)$$

where μ_n , C_{ox} , W/L and I_b are the electron mobility of NMOS, gate oxide capacitance per unit area, transistor aspect ratio and bias current, respectively. The transconductance gain g_m is adjustable by a supplied bias current I_b .

3. Circuit Configuration and Analysis

Fig. 3 shows the mixed-mode biquad circuit configuration. The circuit is constructed with five OTAs and two grounded capacitors.

Routine analysis yields the voltage and current outputs ($V_{out}(s)$ and $I_{out}(s)$) given by

$$V_{out}(s) = \frac{N_v(s)}{D(s)} \quad (3) \quad I_{out}(s) = \frac{N_i(s)}{D(s)} \quad (4)$$

where

$$N_v(s) = \frac{1}{g_{m3}} \{ \{ I_{in3}(s) + g_{m2} V_{in2}(s) \} s^2 - \frac{g_{m2}}{C_2} \{ I_{in2}(s) + g_{m1} V_{in1}(s) - g_{m4} V_{in3}(s) \} s + \frac{g_{m1} g_{m2}}{C_1 C_2} \{ I_{in1}(s) + g_{m5} V_{in4}(s) \} \} \} \quad (5)$$

$$N_i(s) = g_{m3} N_v(s) \quad (6)$$

$$D(s) = s^2 + \frac{g_{m2} g_{m4}}{C_2 g_{m3}} s + \frac{g_{m1} g_{m2} g_{m5}}{C_1 C_2 g_{m3}} \quad (7)$$

It is found from the equations above that the circuit can perform the mixed-mode operation by selecting the input and output terminals. And various circuit transfer functions can easily be realized choosing the

input terminals suitably.

In current-mode operation, the way to realize the LP, BP, HP, BS and AP transfer functions is as follows:

Current-mode operation ($V_{in1} = V_{in2} = V_{in3} = V_{in4} = 0$)

LP: $I_{in1} = I_{in}$, $I_{in2} = I_{in3} = 0$

$$T_{LP}(s) = \frac{I_{out}(s)}{I_{in}(s)} = \frac{g_{m1} g_{m2} / C_1 C_2}{D(s)} \quad (8)$$

BP: $I_{in2} = I_{in}$, $I_{in1} = I_{in3} = 0$

$$T_{BP}(s) = \frac{I_{out}(s)}{I_{in}(s)} = -\frac{(g_{m2} / C_2) s}{D(s)} \quad (9)$$

HP: $I_{in3} = I_{in}$, $I_{in1} = I_{in2} = 0$

$$T_{HP}(s) = \frac{I_{out}(s)}{I_{in}(s)} = \frac{s^2}{D(s)} \quad (10)$$

BS: $I_{in1} = I_{in3} = I_{in}$, $I_{in2} = 0$

$$T_{BS}(s) = \frac{I_{out}(s)}{I_{in}(s)} = \frac{s^2 + g_{m1} g_{m2} / C_1 C_2}{D(s)} \quad (11)$$

AP: $I_{in1} = I_{in2} = I_{in3} = I_{in}$

$$T_{AP}(s) = \frac{I_{out}(s)}{I_{in}(s)} = \frac{s^2 - (g_{m2} / C_2) s + g_{m1} g_{m2} / C_1 C_2}{D(s)} \quad (12)$$

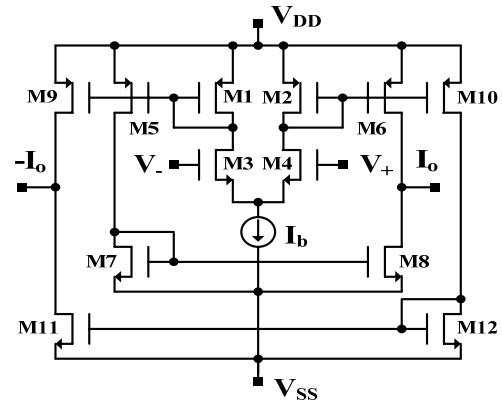

Fig. 2 OTA with MOS transistors.

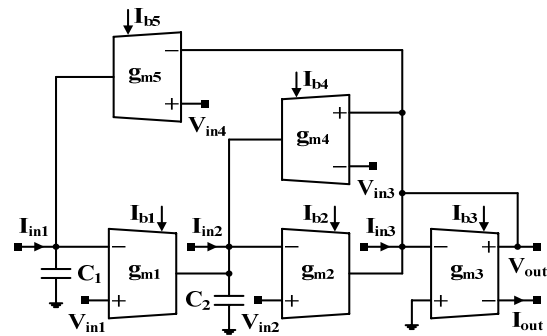

Fig. 3 Mixed-mode biquad circuit configuration.

The circuit parameters ω_0 and Q can be expressed as:

$$\omega_0 = \sqrt{\frac{g_{m1}g_{m2}g_{m5}}{C_1C_2g_{m3}}}, \quad Q = \frac{1}{g_{m4}} \sqrt{\frac{C_2g_{m1}g_{m3}g_{m5}}{C_1g_{m2}}} \quad (13)$$

The circuit parameters ω_0 and Q are tuned orthogonally by adjusting the trans-conductance gains of the OTAs.

The sensitivities with respect to circuit active and passive components (i.e. trans-conductance gains and capacitors) are shown in Table 1. We can find from these values that the biquad enjoys very low sensitivities to the circuit components. It noted that the sensitivities do not depend on the circuit component values.

In the following, we consider to realize the voltage-mode circuit transfer functions. In voltage-mode operation, the LP, BP, HP, BS and AP transfer functions are obtained by selecting the input terminals as follows:

Voltage-mode operation ($I_{in1} = I_{in2} = I_{in3} = 0$)

LP: $V_{in4} = V_{in}$, $V_{in1} = V_{in2} = V_{in3} = 0$

$$T_{LP}(s) = \frac{V_{out}(s)}{V_{in}(s)} = \frac{g_{m1}g_{m2}g_{m5}/C_1C_2g_{m3}}{D(s)} \quad (14)$$

BP: $V_{in1} = V_{in}$, $V_{in2} = V_{in3} = V_{in4} = 0$

$$T_{BP}(s) = \frac{V_{out}(s)}{V_{in}(s)} = -\frac{(g_{m1}g_{m2}/C_2g_{m3})s}{D(s)} \quad (15)$$

HP: $V_{in3} = V_{in}$, $V_{in1} = V_{in2} = V_{in4} = 0$

$$T_{HP}(s) = \frac{V_{out}(s)}{V_{in}(s)} = \frac{g_{m2}}{g_{m3}} \frac{s^2}{D(s)} \quad (16)$$

BS: $V_{in2} = V_{in4} = I_{in}$, $V_{in1} = V_{in3} = 0$

$$T_{BS}(s) = \frac{V_{out}(s)}{V_{in}(s)} = \frac{g_{m2}}{g_{m3}} \frac{s^2 + g_{m1}g_{m5}/C_1C_2}{D(s)} \quad (17)$$

AP: $V_{in1} = V_{in2} = V_{in4} = V_{in}$, $V_{in3} = 0$

$$T_{AP}(s) = \frac{V_{out}(s)}{V_{in}(s)} = \frac{g_{m2}}{g_{m3}} \frac{s^2 - (g_{m1}/C_2)s + g_{m1}g_{m5}/C_1C_2}{D(s)} \quad (18)$$

In addition, the trans-admittance-mode or trans-impedance-mode operation is obtained from selecting the input terminal $I_{in}(s)$ or $V_{in}(s)$ and output terminal $V_{out}(s)$ or $I_{out}(s)$.

4. Design Examples and Simulation Results

As a design example, we consider a realization of

the current-mode circuit characteristic with the cut-off frequency $f_0 (= \omega_0/2\pi) = 1$ MHz, quality factor $Q = 1.0$ and gain constant $H = 1.0$. In this simulation, we have used a macro model of the OTA shown in Fig. 2.

To realize the circuit characteristic above, we have determined that the bias currents and capacitors were $I_{b1} = I_{b2} = I_{b3} = I_{b4} = I_{b5} = 40$ μ A and $C_1 = C_2 = 17$ pF, respectively. Also, we have set the supply voltages and input current at $V_{DD} = -V_{SS} = 1.85$ V and $I_{in} = 10$ μ A.

Fig. 4 shows the simulation responses with PSPICE. Fig. 4a shows the LP, BP, HP and BS responses. The AP response is shown in Fig. 4b. The simulation responses are favorable enough over a wide frequency range. The power dissipation was 4.83 mW.

Fig. 5 shows the simulation responses with f_0 -tuning (i.e. $f_0 = 500$ kHz, 1 MHz and 2 MHz), keeping $Q = 1.0$ and $H = 1.0$. In this case, the capacitors and bias currents were $C_1 = C_2 = 17$ pF and $I_{b3} = I_{b4} = I_{b5} = 40$ μ A, $I_{b1} = I_{b2} = 9.6$ μ A, 40 μ A and 210 μ A, respectively. Fig. 6 shows the simulation responses with Q -tuning (i.e. $Q = 0.707, 1.0, 2.0$ and 5.0), keeping $f_0 = 1$ MHz. In this case, the capacitors and bias currents were $C_1 = C_2 = 17$ pF and $I_{b1} = I_{b2} = I_{b3} = I_{b5} = 40$ μ A, $I_{b4} = 80$ μ A, 40 μ A, 10 μ A and 1.6 μ A, respectively. It is found that the circuit parameters f_0 and Q can be tuned electronically adjusting the bias currents of the OTAs.

In the following, we have considered about the voltage-mode biquad circuit. The circuit parameters f_0 , Q and H are same as the current-mode ones. Also, we have set that the values of the bias currents and capacitors were all the same as the current-mode circuit.

Table 1 Sensitivity to circuit components.

x	$S_x^{\omega_0}$	S_x^Q
g_{m1}	0.5	0.5
g_{m2}	0.5	-0.5
g_{m3}	-0.5	0.5
g_{m4}	0.0	-1.0
g_{m5}	0.5	0.5
C_1	-0.5	-0.5
C_2	-0.5	0.5

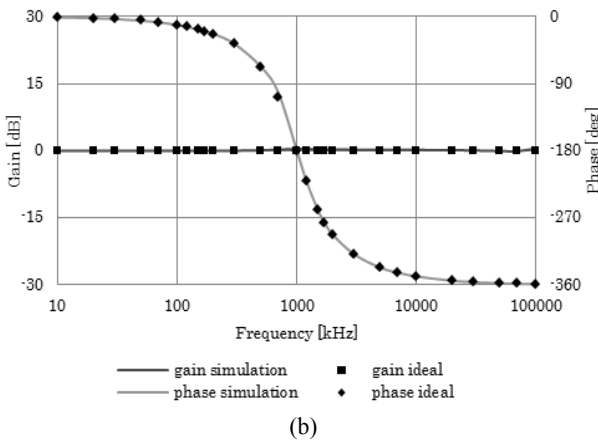
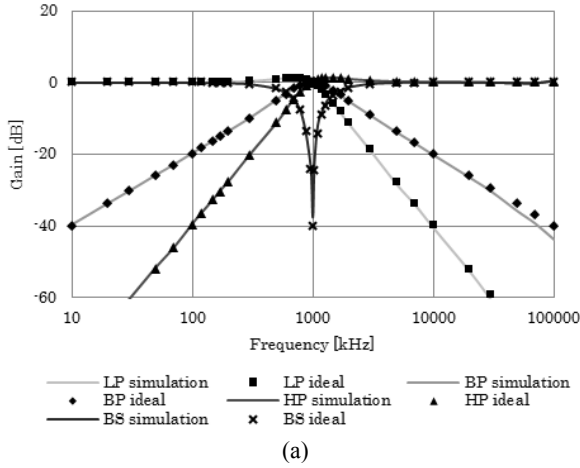

Fig. 4 Simulation responses (current-mode circuit).

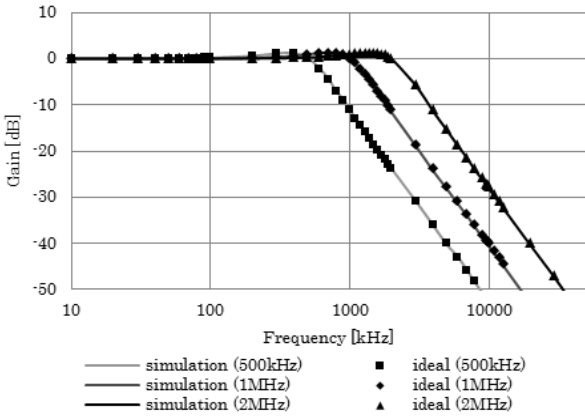

Fig. 5 f_0 -tuning responses (current-mode circuit).

Fig. 7 shows the simulation responses. You can see that the simulation responses are good enough as well as the current-mode ones. Here, we have set the input voltage $V_{in} = 100$ mV. The power dissipation was 4.83 mW.

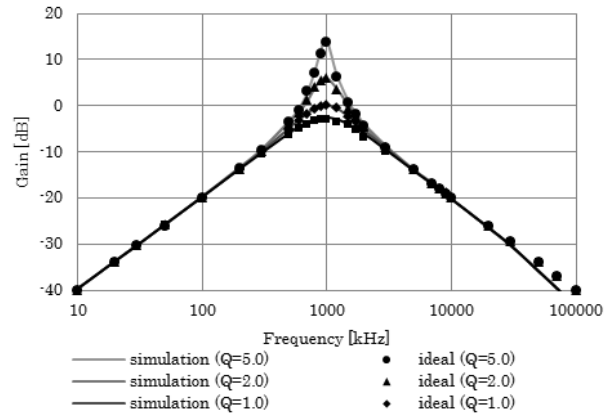

Fig. 6 Q-tuning responses (current-mode circuit).

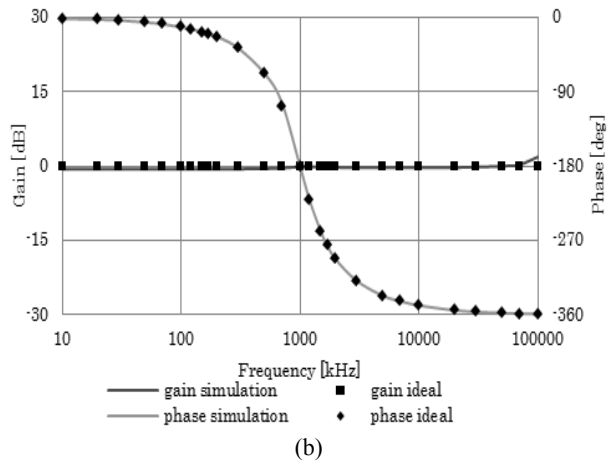
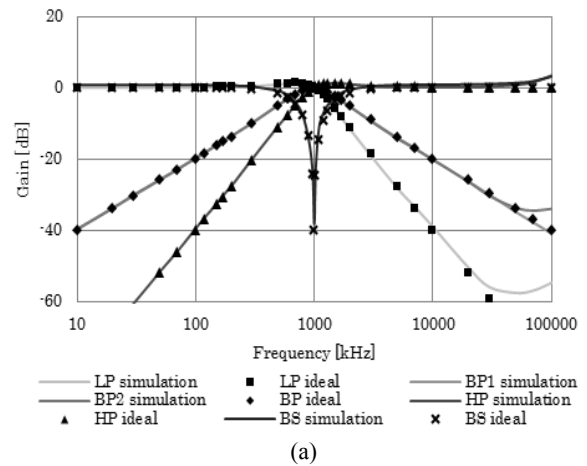

Fig. 7 Simulation responses (voltage-mode circuit).

In this simulation, the size of all the MOS transistors have $W = 4 \mu\text{m}$ and $L = 2 \mu\text{m}$. And we have used the parameters of MOSIS $0.5 \mu\text{m}$ for other device parameters.

5. Conclusions

A mixed-mode biquad employing five OTAs and two grounded capacitors has been proposed. We have demonstrated that the circuit can perform the mixed-mode operation by selecting the input and output terminals, and that the circuit enables LP, BP, HP, BS and AP transfer functions by suitably choosing the input terminals. Additionally, the circuit parameters ω_0 and Q can be tuned orthogonally through adjusting the trans-conductance gains of the OTAs. It has been made clear that the circuit has very low sensitivities to the circuit active and passive components.

The achievement examples have been given together with simulation results by PSPICE. The simulation responses have been appropriate enough over a wide frequency range. The circuit configuration is very suitable for implementation on both bipolar and CMOS technologies.

The non-idealities of the OTA may affect the circuit

characteristics. The solution on this will be discussed in the future.

References

- [1] Abuelma'atti, M. T. et al. 2005. "A Novel Mixed-Mode OTA-C Universal Filter." *International Journal of Electronics* 92 (7): 375-83.
- [2] Bhaskar, D. R. et al. 2005. "New OTA-C Universal Current-mode/Trans-admittance Biquads." *IEICE Electronics Express* 2: 8-13.
- [3] Ramirez-Angulo, J. et al. 1992. "Current-mode Continuous-time Filters: Two Design Approaches." *IEEE Transactions on Circuits and Systems* 39 (6): 337-41.
- [4] Tao, Y., and Fidler, J. K. 2000. "Electronically Tunable Dual-OTA Second-Order Sinusoidal Oscillators/Filters with Non-interacting Controls: A Systematic Synthesis Approach." *ibid.* 47: 117-29.
- [5] Tsukutani, T. et al. 2003. "A Realization of Multiple Circuit Transfer Functions Using OTA-C Integrator Loop Structure." *IEICE Transactions on Fundamentals* E86-A, (2): 509-12.
- [6] Tsukutani, T. et al. 2014. "Electronically Tunable Inverse Active Filters Employing OTAs and Grounded Capacitors." *International Journal of Electronics Letters*, online.