

An Overview of the Possibilities of the Variational Analysis for Exploration of Electric Circuits

Emil Ivanov Panov and Miroslava Grisheva Doneva

Department of Theoretical Electrical Engineering and Instrumentation, Technical University of Varna, Varna, Bulgaria

Abstract: The paper presents an overview of the variational analysis in combination with the transferring coefficients of the EC (electric circuits). In the reference papers the methodologies for DC, AC and transient analysis of linear and non-linear EC are developed. Some examples are presented in order to illustrate the approach.

Key words: Variational approach, variational analysis of electric circuits, basic theorems for variational analysis, methodologies for variational analysis.

1. Introduction

The variational approach is a powerful tool for analysis in mechanics, field theory, quantum mechanics and some other areas of modern science. The first author of the present paper developed four new theorems and the first systematical methodologies for variational analysis with transferring coefficients of EC (electric circuits) in circuit theory [1-7].

Two theorems [1] can be used directly for the variational analysis of all types of regimes in LEC (linear EC) or non-linear EC, because they introduce the bases of such a type of analysis for EC.

First theorem: For each electric circuit, among all sets of currents, which formally satisfy KCL (Kirchhoff's current law) for the nodes of the circuit, there is only one set of currents, for which the instantaneous power of each current source has an extremum (a minimum or a maximum), if this power is not equal to zero. And this set of currents is the only one, which satisfies the equations using Ohm's and Kirchhoff's laws for the circuit.

Second theorem: For each electric circuit, among all sets of voltages, which formally satisfy KVL

Corresponding author: Emil Panov, associate professor, Ph.D., engineer, research fields: circuit and field theory.

(Kirchhoff's voltage law) for the loops of the circuit, there is only one set of voltages, for which the instantaneous power of each voltage source has an extremum (a minimum or a maximum), if this power is not equal to zero. And this set of voltages is the only one, which satisfies the equations using Ohm's and Kirchhoff's laws for the circuit.

The variational analysis of harmonic LEC is comfortably to be introduced in combination with the phasor approach, because of the possibility for algebraization of the solutions. That can be achieved by the help of the next two theorems [5].

Third theorem: For each harmonic LEC, there is only one set of complex branch currents, for which the apparent pseudo-power of any of the current sources in the explored circuit $\left| \dot{S}_{j_{pseudo}} \right|$ has an extremum (a minimum or a maximum), where $\dot{S}_{j_{pseudo}} = \dot{U}_j \cdot \dot{J}$ is the complex pseudo-power of the given source and \dot{U}_j is the complex voltage drop across it.

Fourth theorem: For each harmonic LEC, there is only one set of complex voltage drops across its elements, for which the apparent pseudo-power of any of the voltage sources in the explored circuit $\left| \dot{S}_{E_{pseudo}} \right|$ has an extremum (a minimum or a maximum), where $\dot{S}_{E_{pseudo}} = \dot{E} \cdot \dot{I}_E$ is the complex

pseudo-power of the given source and $\dot{I}_{\dot{E}}$ is the complex current, flowing through it.

The analysis of DC and AC EC needs corresponding methodologies, which give the order of the operations necessary for the optimization of the calculation procedures. Such methodologies are presented for DC and AC analysis of linear EC, for DC analysis of non-linear EC and for analysis of transient processes in non-linear EC. They are illustrated by corresponding examples.

2. Variational Analysis of EC

2.1 Short Theory of the Variational Analysis of DC and AC LEC

The variational analysis of one LEC working at DC regime by the help of the basic laws for EC can be conducted by the following methodology:

(1) A reference source (a source of electromotive current (e.m.c.) with a current j_1 or a source of electromotive force (e.m.f.) with a voltage e_1) is selected in the circuit being studied. A pair of terminals (a) and (b), separating the circuit into a reference source and a resistive part, is introduced, while all other sources are considered to be resistors according to the compensation theorem with positive or negative resistances R_{eq} or R_{js} .

(2) A number of m transferring coefficients k_1, k_2, \dots, k_m are introduced in relation to the currents through the elements (the voltage drops upon them) having in mind KCL (or KVL).

(3) One equation is created by the help of the balance of the powers, where the power of the reference source is on the left hand side and on the right hand side the powers of the resistive elements are situated:

$$\begin{aligned} P_{j1} &= u_{j1} j_1 = const. = \\ &= R_1 (k_1 j_1)^2 + R_2 (k_2 j_1)^2 + \dots + R_p (k_p j_1)^2 \quad (1) \\ &+ \sum_{q=1}^{vs} (\pm R_{eq} (k_q j_1)^2) + \sum_{s=1}^{cs} (\pm R_{js} (k_s j_1)^2) \end{aligned}$$

or

$$\begin{aligned} P_{e1} &= e_1 i_{e1} = const. = \\ &= G_1 (k_1 e_1)^2 + G_2 (k_2 e_1)^2 + \dots + G_p (k_p e_1)^2 \quad (2) \\ &+ \sum_{q=1}^{vs} (\pm G_{eq} (k_q e_1)^2) + \sum_{s=1}^{cs} (\pm G_{js} (k_s e_1)^2) \end{aligned}$$

where vs is the number of the sources of e.m.f. and cs is the number of the sources of e.m.c.

(4) A system of $(m-1)$ equations is created by the help of KVL (or KCL) and the system is solved taking into account one of the coefficients to be a parameter, for example k_1 .

(5) The equation for the power (1) or (2) is differentiated by k_1 : $\frac{\partial P_{j1}}{\partial k_1} = 0$ or $\frac{\partial P_{e1}}{\partial k_1} = 0$. In the

last equation, we have to substitute $R_{eq} = \frac{e_q}{i_q(k_1)}$

and $R_{js} = \frac{u_{js}(k_1)}{j_s}$, and the equation can be solved in

respect of k_1 analytically or by a suitable numerical method. Based on the obtained value of the transferring coefficient k_1 , the other $(m-1)$ coefficients are calculated and the currents and the voltages of the circuit as well.

Example 1: A circuit is given in Fig. 1 with the following parameters: $R_1 = 30\Omega$; $R_2 = 20\Omega$; $R_3 = 10\Omega$; $j = 5A$; $e = 40V$. Determine the branch currents i_1 , i_2 and i_3 by the variational approach.

Solution:

The source of e.m.c. j is selected for a reference source. The resistive part of the circuit comprises the resistances R_1 , R_2 , R_3 and $R_e = \frac{e}{i_3}$. A transferring

coefficient k is introduced for the current i_2 , i.e. $k = \frac{i_2}{j}$ and applying formally KCL for node (1) we

have: $i_1 = j$, $i_2 = kj$ and $i_3 = (1-k)j$.

Then, the equation for the balance of powers of the circuit is created—its LHS represents the power of the circuit's reference source, which is assumed to be a constant, and its RHS is a sum of the resistive

elements' powers.

$$P_j = u_j j = const = R_1 j^2 + R_2 (kj)^2 + R_3 [(1-k)j]^2 + R_e [(1-k)j]^2 \quad (3)$$

Eq. (3) is differentiated by k and the result is as follows: $\frac{\partial P_j}{\partial k} = 0$. After the differentiation of Eq. (3), we substitute $R_e(k) = \frac{e}{(1-k)j}$ and then, it follows, that $k = 0,6$.

The branch currents we have been looking for in the circuit are the following: $i_1 = j = 5A$, $i_2 = kj = 3A$ and $i_3 = (1-k)j = 2A$.

In Fig. 2 the dependence of the power of the reference source P_j versus the value of the transferring coefficient k is presented.

The minimum of P_j is very well seen from that graph.

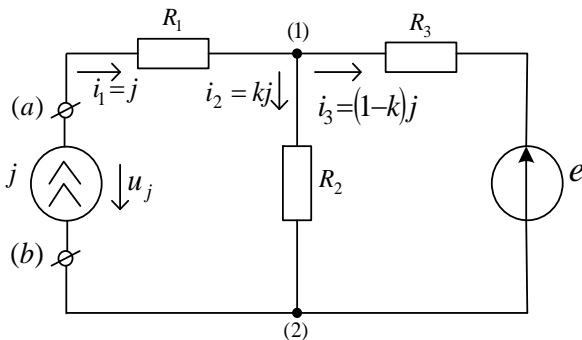

Fig. 1 The circuit from example 1.

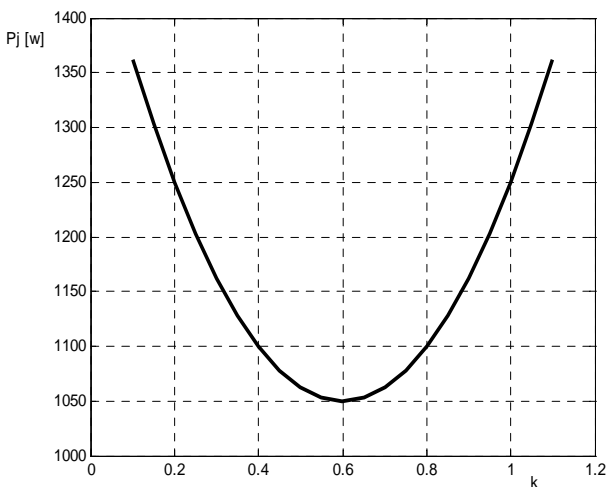

Fig. 2 The power of the reference source P_j versus k .

The variational analysis of harmonic LEC is similar to the DC analysis and it must be conducted in combination with the phasor approach. The methodology for analysis of that regime needs the introduction of the complex pseudo-power of the reference source: \dot{S}_j^{pseudo} or \dot{S}_E^{pseudo} . The methodologies, which combine the variational approach with the loop analysis or the nodal approach for both regimes (DC and AC) are presented in papers [5, 6].

2.2 Short Theory of the Variational Analysis of DC Non-linear EC

In circuit theory there are no well-developed overall analytical methods for exploration of DC regimes by the help of the variational approach. So far, the known methods for variational approach are particular and they provide a solution to specific types of non-linear problems. The application of the variational approach with transferring coefficients for analysis of non-linear EC can be done by applying common methodologies, the same for each non-linear circuit working at DC regime. The variational analysis with transferring coefficients can be applied to any non-linear electric circuit regardless of the number and the type of the included non-linear elements. The three methodologies for analysis, which were introduced in paper [8], allow the application of the variational approach for analysis of non-linear EC using directly the basic laws for the EC, the loop analysis or the nodal approach.

2.3 Variational Approach for Analysis of Transient Processes in Non-linear EC

The analysis of transient processes in EC by the help of the variational approach needs a little bit different procedure, because the basic calculation technology is numeric one (especially for the analysis of non-linear electric circuits) [9].

The methodology for numeric variational analysis

of the transient processes in one EC (for example with one reactive element) has the following steps:

(1) A reference source is selected in the circuit being studied. The other sources can be substituted by positive or negative resistances $R_{eq}(t)$ or $R_{js}(t)$ according to the compensation theorem.

(2) A number of m transferring coefficients k_1, k_2, \dots, k_m are introduced in relation to the currents flowing through the elements (the voltage drops upon them).

(3) One differential equation of the following normalized form can be created for the explored circuit:

$$\frac{dk_1(t)}{dt} = f[k_1(t); R_1; \dots; R_q; C \text{ (or } L)] \quad (4)$$

which will be the predictor of the calculating process. Then, several initial values of $k_1(t)$ can be calculated by the help of the method Runge-Kutta-4 for the first p steps with a step size h in the time interval $(t_0; t_p)$.

(4) Another equation can be created on the base of the balance of powers for the instantaneous powers of the elements of the explored circuit:

$$\int_{t_0}^{t_p} P_{R.E.}[k_1(t)]dt = W_{R.E.}[k_1(t_p)] - W_{R.E.}[k_1(t_0)] \quad (5)$$

where $P_{R.E.}$ is the instantaneous power of the reactive element and $W_{R.E.}$ is the corresponding accumulated energy. That equation will be the corrector of the calculation process. The procedure is maintained by the usage of an iteration procedure and a numeric integration formula of Newton-Cotes of rank higher than 4 (for example 6th order integration formula).

(5) By the help of the predictor – Eq. (4), we can get the next value $k_1(t_{p+1})$, which we can improve by the corrector – Eq. (5).

Example 2: A non-linear circuit is presented in Fig. 3, where: $R_1=120 \Omega$; $R_2=5 \Omega$; $R_3=0,2 \Omega$; $j = 25/12 \text{ A}$; $i_L(t) = 0,5 \Psi_L^2(t)$. Find the current

flowing through the coil $i_L(t)$ by the help of the variational approach.

Solution:

The exact solution of that task is as follows:

$$i_L(t) = k(t).j = 0,5 \left(\frac{3 - 2e^{-250t}}{1,5 + e^{-250t}} \right)^2 \text{ A .}$$

The explored circuit contains a single non-ideal current source. The current flowing through the non-linear coil can be expressed as: $i_L(t) = k(t).j$.

Then:

$$u_L(t) = \frac{d\Psi_L(t)}{dt} = \frac{d}{dt} [\sqrt{2.i_L(t)}] = \frac{dk(t)}{dt} \cdot \sqrt{\frac{j}{2.k(t)}}$$

and

$$i_1(t) = j[1 - k(t)].$$

Using KCL and KVL we can express the voltage drop $u_j(t)$, i.e. $u_j(t) = R_1.i_1(t) = R_1.j[1 - k(t)]$ and we can also find the connection among $u_j(t)$, $i_L(t)$ and $u_L(t)$:

$$u_j(t) = R_2 i_L(t) + u_L(t).$$

From here, we receive the predictor equation:

$$\frac{dk(t)}{dt} = \sqrt{2 k(t).j} \cdot [R_1 - (R_1 + R_2).k(t)] .$$

The corrector of the calculation process will have the following form:

$$\int_{t_0}^{t_6} [p_j(t) - p_{R_1}(t) - p_{R_2}(t)] dt = \int_{t_0}^{t_6} p_L(t) dt ,$$

i.e.

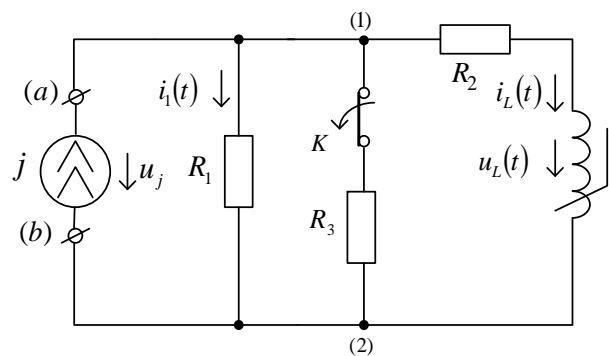

Fig. 3 The circuit from example 2.

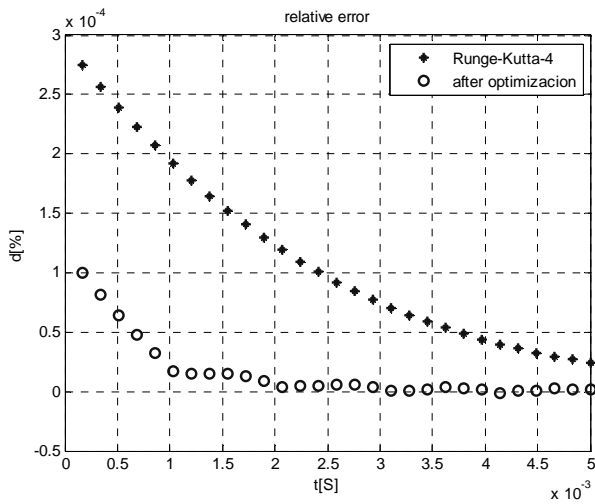

Fig. 4 The relative error d versus time t .

$$k(t_6) = \left\{ \begin{array}{l} 2,5\sqrt{1,5} \int_{t_0}^{t_6} [R_1 k(t) - (R_1 + R_2)k^2(t)] dt + \\ + k^{3/2}(t_0) \end{array} \right\}^{2/3}$$

Here, the numeric integration can be fulfilled by the 6th order Newton-Cotes formula. After we have already improved the six initial values of the transferring coefficient $k(t)$, we can improve the seventh one - $k(t_7)$, too.

In Fig. 4 the relative error d is presented for two calculation procedures—the Runge-Kutta-4 method and the optimized numeric solution of the variational approach. Here, the step size is accepted to be $h = \frac{1}{3} ms$.

3. Conclusion

The variational analysis with the transferring coefficients is a new approach for analysis of EC. Maybe it is the eleventh one according to the classification of the authors of the paper. Its application is supported by the introduction of four new theorems for EC, two rules for introduction of the transferring coefficients and several methodologies for analysis of DC, AC regimes in EC and transient processes, too.

The variational analysis is more difficult to use

compared with the well-known methods for analysis of EC, but it has something additional compared with the rest of the methods. All methods obey to two basic laws of nature - the charge conservation law (with its consequence - KCL) and the energy conservation law (with its consequence - KVL). The variational analysis except them uses also the balance of powers, which is in connection with the least action principle, which all physical processes in nature obey to. This fact gives an additional tool to the variational approach to have an exclusive instrument to precise the errors of the calculated values of the currents and the voltages in the explored EC. Except that, the variational analysis can be accomplished in matrix form, too [3, 4]—a fact, which makes that approach able to use automated computer-aided calculations. So, circuit theory may become only more powerful after the development and introduction of the new methodologies for variational analysis of EC by the help of the transferring coefficients.

The proposed methodology for variational analysis of transient processes in non-linear EC can be ever introduced successfully, because we can always choose a corrector of higher order, compared with the order of the predictor, having in mind that the integration equations of Newton-Cotes form an infinite family of high-precision formulas. The truncation error of the method Runge-Kutta-4 is $\varepsilon_{T.R.K.} = \frac{h^5}{5!} f^{(V)}(\xi)$, where ξ is some point within the time interval of the last step h of the calculation process. The sixth order integration formula of Newton-Cotes has an error:

$$\varepsilon_{T.N.C.} = -\frac{h^7}{1400} [10.f^{(VI)}(\xi) + 9h^2.f^{(VIII)}(\eta)],$$

where ξ and η are some points within the integration interval $[t_k; t_{k+6}]$. So, for $h \ll 1$ it is clear, that $\varepsilon_{T.R.K.} \gg \varepsilon_{T.N.C.}$, which allows Newton-Cotes formulas of higher order to be in the base of the corrector integration equations.

The proposed variational approach is more complex compared with the classic solutions. It is better to use it for analysis of transient processes in non-linear electric circuits, especially in cases when there are no exact classic solutions. The optimization procedures implemented in the variational method give the possibility to improve the numeric solutions and to increase the accuracy of the final results.

References

- [1] Panov, E. I. 1995, 1996. "Variation Method for Analysis of Electric Circuits." *Proceeding of the Union of the Scientists - Varna 2*, 1: 56-9.
- [2] Panov, E. I. 1995, 1996. "Exploration on the Possibilities of the Variation Method for Analysis of Electric Circuits." *Proceeding of the Union of the Scientists - Varna 2*, 1: 60-2.
- [3] Panov, E. I. 1997. "Computer-Aided Analysis of Electric Circuits by Variation Method." In *Proceedings of the 11th International Conference Systems for Automation of Engineering and Research and DECUS NUG Seminar (SAER'97)*, Varna, Bulgaria, 227-31.
- [4] Panov, E. I. 1999. "New Approaches for Implementation of the Variation Method for Analysis of Electric Circuits." In *Proceedings of the International Conference "Days of the Science of Republic of Bulgaria and Republic of Macedonia"*, Sofia, Bulgaria, 348-61.
- [5] Panov, E. I., and Doneva, M. Gr. 2014. "Phasor Approach for Variation Analysis of Electric Circuits." In *Proceedings of the International Scientific and Technical Conference Electrical Power Engineering-2014*, Varna, Bulgaria, 71-80.
- [6] Panov, E. I., and Doneva, M. Gr. 2014. "Exploration of the Possibilities for Variation Analysis of Complex Electric Circuits Combined with the Loop Analysis and the Nodal Approach." In *Proceedings of the International Scientific and Technical Conference Electrical Power Engineering-2014*, Varna, Bulgaria, 81-8.
- [7] Panov, E. I., and Doneva, M. Gr. 2014. "Exploration of the Possibility of the Method with the Transferring Coefficients Combined with the Variation Approach for Analysis of Electric Circuits." *Annual of the Technical University of Varna 1*: 79-84.
- [8] Doneva, M., and Vasileva, V. 2015. "Exploration of the Possibilities for Analysis of Non-linear Electric Circuits Working at DC Regimes Using Variational Approach." In *Proceedings of the XIV-th International Conference on Electrical Machines, Drives and Power Systems-ELMA'2015*, Varna, Bulgaria, 81-90.
- [9] Panov, E., and Doneva, M. 2015. "Exploration of the Possibilities of the Variational Approach for Analysis of Transient Processes in Electric Circuits." In *Proceedings of the XIV-th International Conference on Electrical Machines, Drives and Power Systems-ELMA'2015*, Varna, Bulgaria, 305-12.